

RFID-Based Multidisciplinary Educational Platform to Improve the Engineering and Technology Curriculums

Kumar Yelamarthi

Central Michigan University

Abstract

Multidisciplinary projects involving electrical engineering (EE), mechanical engineering (ME), and computer engineering (CE) students are both exciting and difficult to conceptualize. Answering this challenge, this paper presents a multidisciplinary educational platform on radio frequency identification-based assistive devices. The combination of software, hardware, circuit, and mechanical design makes this platform an excellent choice for undergraduate student projects and curriculum development.

Through working on these multidisciplinary projects, students will be able to study a complex engineering and technology system that: a) exposes them to applied and cutting-edge technologies, b) encourages them to participate in an integrated, multidisciplinary curriculum, and c) trains them in methods of applied technology and the skills necessary to transition from academic to professional environments.

1. Introduction

The rapid advancement in technology has laid a path for the design and manufacture of many multidisciplinary integrated technologies. These advancements have provided new avenues for the engineering educators to better prepare tomorrow's global citizens through innovative methods capable of responding to the future challenges, such as an aging society, a higher need for assistive devices, and methods to integrating new developments into the society (National Academy of Engineering, 2004). On the other hand, engineering educators are faced with a challenge of low student enrollment in Science, Technology, Engineering, and Mathematics (STEM) disciplines, resulting in a low graduation rate of STEM professionals in United States (US) compared to that of other nations (National Science Board, 2012). For the US to continue being the global leader in engineering and technology, engineering educators need to be proactive in preparing tomorrow's global citizen through integrated and innovative multidisciplinary approaches.

While proposing solutions for a technical problem, conventional design projects in the engineering curriculum limit the scope to just one discipline, and focus on improvement rather than innovation (Dutson, Todd, Magleby, & Sorenson, 1997). A student-focused curriculum should be designed to address one such drawback. Undergraduate education is a stimulating and nurturing process during which students are open and eager to learn new concepts, and it is up to engineering educators to provide appropriate opportunities to actively engage and guide students. On one hand engineering education requires the adaptive grasping of basic theories, but on the other hand, it emphasizes hands-on experiences, innovative ideas and creativity to meet societal needs. Accordingly, there is a genuine necessity to bridge the gap between theory and practice (Haddara & Skanes, 2007).

Two such critical success factors for engineers in the "flat-world" are their ability to adapt to changes and their ability to collaborate with others from different disciplines (Friedman, 2005; Schaefer, Panchal, Choi, & Mistree, 2008). In this "flat-world", engineers and scientists need to constantly learn and teach others new ways of performing old/new tasks, and also to learn how to collaborate. By collaborating across disciplines, students: a) obtain opportunities to experience a different domain, b) combine knowledge and skills from different disciplines, c) work as a team members, d) solve real-time design/research problems, and e) gain personal and professional development opportunities (Skates, 2003).

ABET recommends engineering programs that focus on theory, where engineering graduates spend their time planning, solving problems, designing and developing new products, systems, and technologies. Technology graduates would focus on product design and application of these new technologies (ABET, 2012). A multidisciplinary and integrated platform for the collaboration of engineering and technology students answers few of the challenges in this "flat-world," such as globalization, an ability to adapt, and collaboration between different disciplines and cultures (Friedman, 2005). Rooted in the key disciplines of Electrical Engineering, Mechanical Engineering, Chemical Engineering, and industrial technology, the Radio Frequency Identification based Assistive Devices (RFID-AD) platform teaches students how to collaborate on projects of national importance, and highlights the significance of engineering and technology in socio-cultural aspects (Scherer & Glueckauf, 2005). Additionally, this platform is in accordance with the National Academy of Engineers recommendation that, "Engineering schools should introduce the multidisciplinary learning in the undergraduate environment, rather than having it as an exclusive feature of the graduate program" (National Academy of Engineering, 2004).

2. RFID System Operation

Recent technological advancements in wireless communication systems, sensors, and hardware have made it possible for easy implementation of solutions that were once thought to be very difficult. One such technology is Radio Frequency Identification (RFID) that relies on remotely storing and retrieving data using tags and readers. The convergence of this RFID, and other wireless, technology lies at the heart of many novel applications, such as remote medicine, intelligent transportation system, access control, wireless remote sensing, remote warehouse management, early warning systems, and locating points of interest (Chawla & Robins, 2011).

A typical RFID system is comprised of four fundamentals components as seen in Figure 1. The first component is the host computer used to store application software, read/write data from/to the tags through the reader, perform arithmetic and logical operations, and serve as an intermediate interface between the reader and applications. The second component is the RFID reader that receives commands from the application software, communicates with the RFID tag via the antenna, and provides power to passive tags. The third

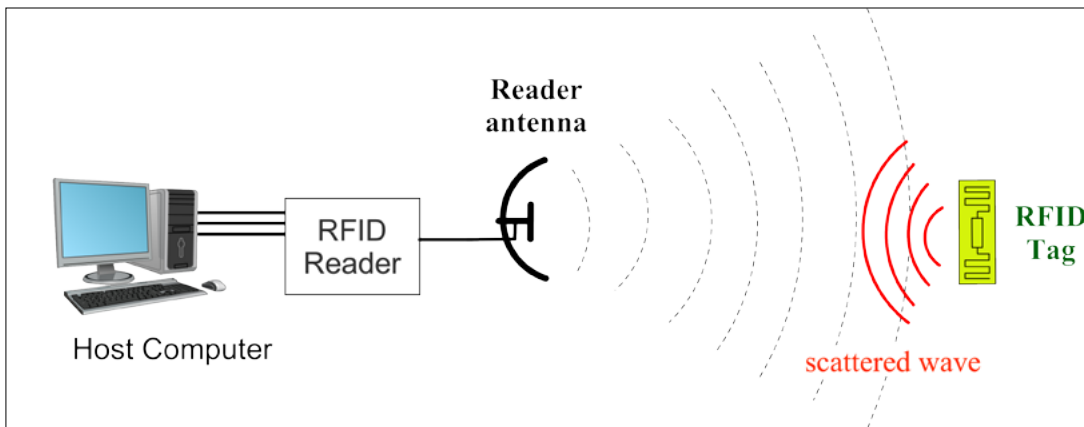

Figure 1: Overview of RFID System

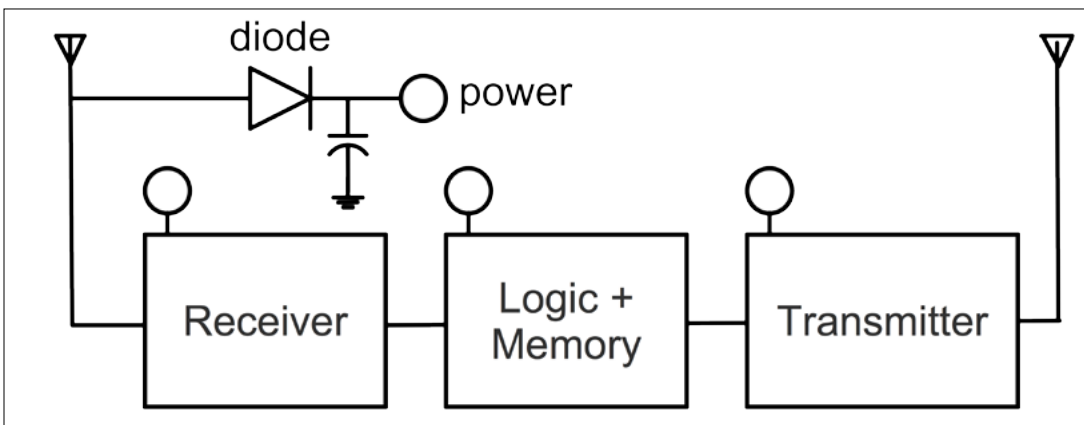

Figure 2: Extraction of DC Power by the Passive RFID Tag [Cardullo et al 1973]

component is the reader antenna used to transmit/receive a RF signal to/from the RFID tag. The fourth component is the RFID tag that includes a small integrated circuit (IC) that stores a unique identification information (UID), and an onboard antenna to communicate with the RFID reader.

While in operation, the RFID reader through the antenna transmits an RF signal, which is received by the onboard RFID tag antenna. Once the onboard antenna on the RFID tag detects this RF signal, it passes the alternating polarity signal through a diode to extract DC power, activates the IC, loads the UID on the RF signal, and transmits the RF signal as in Figure 2 using backscattering technique (Nikitin & Rao, 2006). The RFID reader detects this backscattered signal, decodes the UID, and communicates it to the respective application through the host computer (Nikitin & Rao, 2006).

3. Necessity for Assistive Devices

In December of 2008, the US Census Bureau reported that 54.4 million (19 percent of the population) Americans have disabilities (U.S. Census Bureau, 2008). In January of 2009, the employment-population ratio for people with disability was 20 percent, compared with 65 percent for people with no disability (Bureau of Labor Statistics, 2009; "Occupational outlook handbook," 2009). There are many other alarming data points about this segment of population. For example:

- Three times as many (26 percent vs. 9 percent) live in poverty.

- Half (50.3 percent) have family annual incomes of less than \$20,000.
- People with disabilities are twice as likely to drop out of high school (21 percent vs. 10 percent).
- They are twice as likely to have inadequate transportation (31 percent vs. 13 percent).
- More than twice as many go without health care (18 percent vs. 7 percent).
- Two out of three capable of working are currently unemployed.
- The number of people pursuing higher education is very low.
- 16.3 percent of the US population suffers from some sort of disability as shown in Figure 3 (Bureau of Labor Statistics, 2009).

Given the persistence of the above gaps, it is not surprising that the life satisfaction for people with disabilities is also significantly lower. As the average life span is predicted to increase along with the population by 2020, it is clear that the number of people with disabilities is going to

increase proportionately (National Academy of Engineering, 2004). Although the legislation has helped to increase awareness of the barriers in health care facilities, transportation, workplaces, and elsewhere, its implementation and enforcement have often been disappointing (Field & Jette, 2007). With the unemployment rate increasing and life satisfaction decreasing for this segment of

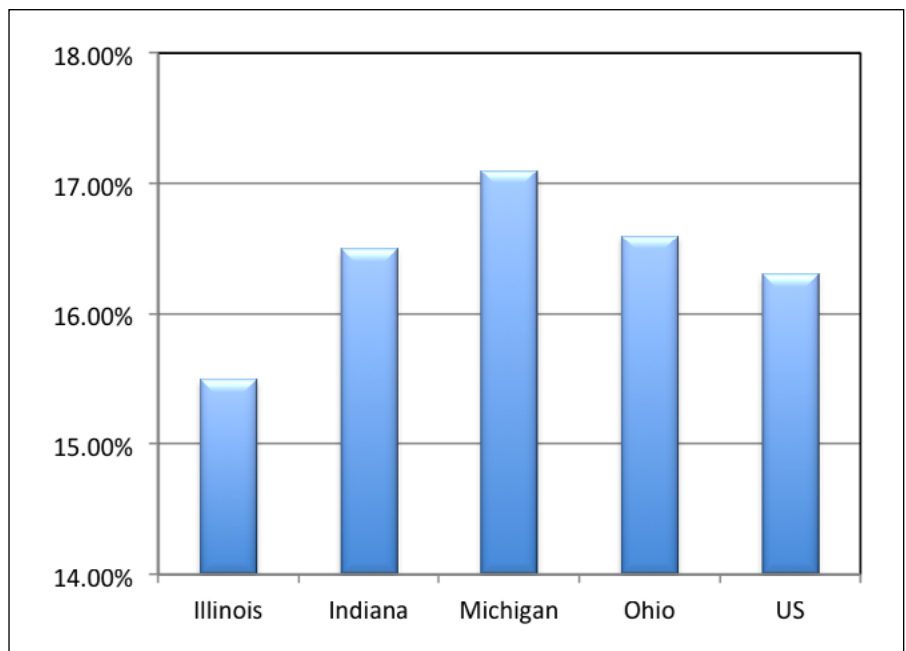

Figure 3: Percentage of Population with Disabilities

US Population (16 to 64 age)	178687234
Employment disability	21287570
Physical Disability	11150365
Sensory Disability	4123902
Mental Disability	6764439
Self-Care	3149875
Difficulty going outside	11414508

Table 1: Distribution of Population with Disabilities
[Bureau of Labor Statistics, 2009]

population, there is an impending requirement for the design of new assistive devices (Field & Jette, 2007).

Table 1 shows the distribution of the population with disabilities, where the majority could be assisted to become a part of regular learning environment through an assistive device (Bureau of Labor Statistic, 2009; Field & Jette, 2007; Cavanaugh, 2002; Hefzy, Pourazady, & Afjeh, 2008; Terpenney, 2006). One priority in this process is to identify good strategies to develop and bring to market the improved and accessible mainstream assistive technologies, such as an automated wheel chair or a smart-robot for the blind (Yelamarthi, Haas, Nielsen, & Mothersell, 2010). The design and manufacture of these assistive devices does not depend on just one engineering discipline, but on the multidisciplinary collaboration. The engineering and technology (ET) education community must take advantage of assisting the disabled through an integrated curriculum that allows the ET students to participate in the design and development of new assistive devices.

Involvement in such a student-focused multidisciplinary curriculum will help students re-conceptualize their view of ET in a context that addresses a societal need that is driven and influenced by the global marketplace for engineering services of the future (National Academy of Engineering, 2004). In addition, students working on assistive devices is in line with the recommendation of National Science Board (2007; 2005) that, "Engineering thinking needs to be able to deal with complex interrelationships that include not only traditional engineering problems, but also encompass human and societal problems as major components; and engineering schools should provide opportunities to work for the public good, to take advantage of student interest in public service."

4. RFID based Assistive Device Platform

Sternberg, Johnson, Moen and Hoover (2000) (stated that the pedagogical purpose of capstone design projects is to provide students an opportunity to experience how content in undergraduate curriculum links together to provide a coherent vision of the knowledge necessary to complete a significant engineering project. Upon completion of the capstone design project and graduation, students enter the professional workforce where they typically work in multidisciplinary teams, requiring a good understanding of other disciplines for effective communication. As communication is a skill that develops through practice, students need to be trained significantly prior to graduation. Furthermore, the rapid advancement in technology is mandating engineering educators to introduce

new concepts in the ET curriculum and prepare students accordingly. As it is not feasible to increase the number of courses required for graduation, new methods of educating students about cutting edge technology in the existing curriculum are necessary.

RFID technology has emerged as one of the most advanced and promising types of real-world awareness technologies in recent years (Car Anti-Theft Prevention, 2002; O'Connor, 2009; Swedberg, 2010). Topics in RFID add an exciting dimension to the student's educational experience, and fit seamlessly into an established ET curriculum (Cavanaugh, 2002). Based on the concepts students learned from core ET classes, students could design a product utilizing this new technology. However, constant motivation is required for students to learn new technologies and implement new concepts. Demonstrating the applicability of their work to enhance the societal needs of the community, such as helping people with disabilities, provides this required motivation. Therefore, the multidisciplinary RFID-AD platform is the ideal educational platform to answer the rising challenges of preparing the future engineers and technologists to meet the society's needs.

One primary advantage in the RFID-AD platform is that, instead of each student team initiating a project from the very basics, they can work to advance the project on a platform that has been initiated. This saves ample time for the students, provides them an opportunity to gain a deeper understanding of fundamental concepts, and focuses on research aspects in the integrated and multidisciplinary project. Overall, the RFID-AD projects have potential to encompass several technical concepts from the ET disciplines as shown in Table 2. The labs and projects resulting from this program can be integrated into the existing ET curriculum, and potentially assist towards course improvements as listed in Table 3.

Overall, RFID-AD is a good platform for student projects because (a) it requires collaboration of multiple disciplines, (b) it addresses the requirement for new assistive designs which are predicted to increase in the future, (c) it deals with the societal aspects of engineering and technology, (d) it has huge potential for undergraduate research and design projects, and (e) it helps aspiring ET professionals to gain a deeper understanding of problems faced in the daily life of people with disabilities, demonstrating the prominence of ET disciplines.

5. RFID Based Assistive Device Projects

5.1. RFID based Smart-Robot: A navigation assistive device for the blind

According to the National Center for Health Statistics, approximately 25.2 million people in the US have trouble seeing, even wearing glasses or contact lenses (Center for Disease Control, 2008). Two primary challenges that visually impaired people face every day are mobility and orientation. Less than 10 percent of visually impaired people in the US use canes and approximately 2 percent use guide dogs (Guide Dogs, 2012). The RFID based Smart-Robot (SR) presented answers to the challenge of helping a visually impaired person navigate safely.

Computer/Electrical Engineering	Mechanical Engineering	Industrial Technology
Wireless Communication Signal Processing Circuit Design Robotics and Automation Embedded Systems Computer Programming	Structural Dynamics Engineering Materials Machine Design Failure Mode Analysis Design for Manufacturability	Plastics/Metal Technology Applied Electronics Computer Aided Design Power & Energy Technology Parametric Design & Modeling

Table 2: Technical Concepts Covered in the RFID-AD Platform

Course (Discipline)	Course Objectives & Potential Improvements
EGR 120: Introduction to Engineering (EE, CE, ME, IET)	<p><i>Course Objectives:</i> Upon successful completion of this course, the students will be able to: a) describe the engineering profession and its various disciplines, b) apply the basic problem solving skills of engineering, c) work in teams, and d) apply the engineering design process to a broad variety of design projects</p> <p><i>Potential Improvements:</i> Freshman students can gain hands-on exposure to real-time designs/experiments designed from the RFID-AD platform. Through this exposure, learning appropriate instrumentation and data analysis, and how multidisciplinary teams work, they will be well prepared to step forward into research projects early in their undergraduate education.</p>
IET 170: Metal Technology (IET) IET 365: Plastics Technology (IET)	<p><i>Potential Improvements:</i> Through analyzing prototypes from the RFID-AD platform, students can gain better understanding of the manufacturing process in machining and casting, while learning about CAD drawings, blueprints, process sheets, and methods used to produce products in a timely fashion. This method will provide students a broader perspective of concept implementation in technology devices, and help them to progress forward in their technology curriculum.</p>
EGR 359: Machine Design (ME, IET)	<p><i>Course Objectives:</i> Upon successful completion of this course, the students will be able to: a) design common machine elements using linkages, cams and gear trains, b) carry out positional analysis of mechanisms, c) carry out velocity analysis of mechanisms, d) carry out acceleration analysis of mechanisms, and e) determine dynamic forces in machines.</p> <p><i>Potential Improvements:</i> By performing extensive data collection and analysis from RFID-AD prototypes, students can learn the limitations and good strategies in machine design. This analysis will further increase the student knowledge base and demonstrate the critical design principles behind successful machine design.</p>
EGR 396: Microprocessor Fundamentals (EE, CE)	<p><i>Course Objectives:</i> Upon successful completion of this course, the students will be able to: a) design, simulate, and build microcontroller-based embedded systems, b) implement interrupts in their designs, c) make use of microcontroller features including A/D converters, real time clocks, and d) make use of external peripherals devices in their design projects</p> <p><i>Potential Improvements:</i> The real-time projects from the RFID-AD platform can be used to highlight the significance of stack operations, subroutines, parameter passing, interrupts, bus/memory/timing characteristics, and memory interfacing in a microprocessor system. This broader perspective will enhance student skills in writing computer programs that are efficient in terms of high speed, and low CPU utilization.</p>
EGR 481: Embedded System Design (EE, CE)	<p><i>Course Objectives:</i> Upon successful completion of this course, the students will be able to: a) describe the architecture of Motorola 68HC12 microcontroller family, b) design the interface hardware to connect the microcontroller to different types of I/O devices, c) program the microcontroller using interrupt synchronization in multithreaded environment, and d) design systems for real-time applications such as real-time signal processing and real-time control.</p> <p><i>Potential Improvements:</i> As the primary focus of embedded systems is integrating and interfacing different devices, the RFID-AD projects can be used to demonstrate efficient strategies in designing a system to meet desired needs within realistic constraints, such as economic, social, ethical, manufacturability, and sustainability. These methods teach students the effective strategies for designing embedded systems, while cultivating ethical standards in the process.</p>

Table 3: Potential Course Improvements from RFID-AD Platform

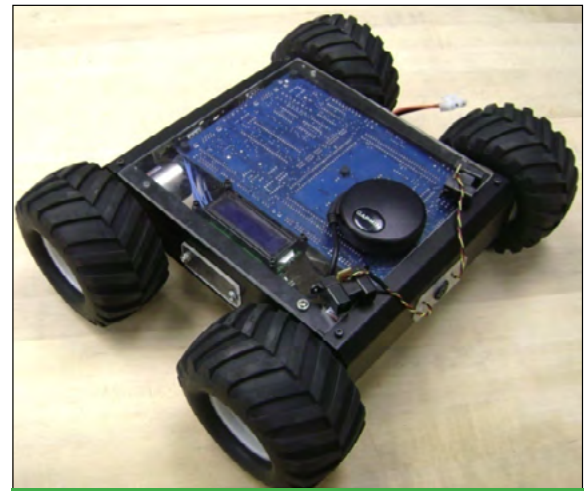

Figure 4: RFID based Smart-Robot Prototype

During the fall semester of 2009, two students from electrical engineering and one student from mechanical engineering collaborated to successfully design the RFID based smart-robot shown in Figure 4 (Yelamarthi, Haas, Nielsen & Mothersell, 2010). The SR uses UID on RFID tags to store location information for indoor localization, and GPS for outdoor localization. This portable SR is comprised of an embedded system equipped with an RFID reader, GPS, and analog compass as input devices to obtain location and orientation. It can guide the user to a predefined destination, or create a new route on-the-fly for later use. While in navigation mode, it aids the user to reach the destination by avoiding obstacles using ultrasonic and infrared sensor inputs. The smart-robot also provides user feedback through a speaker, and vibrating motors on the glove (not shown in the picture, but tethered through a cable from the back side of the smart-robot) to detect obstacles and suggest directional changes during navigation.

The navigation algorithm for the Smart-Robot is shown in Figure 5. Operation of the smart-robot start by turning on the master power switch, after which the system will beep and vibrate all motors on the glove to notify the user that the device is ready for navigation assistance. Through the speaker, SR will ask if the user intends to use a predefined route, or create a new route. If the user intends to use a predefined route, SR will ask for route origin and destination. Upon input from the user, it will retrieve the route coordinates from the appropriate route file, and load them on a route array " $ra = \{i, i+1, \dots, k\}$ ". Next, it will obtain the current longitude and latitude coordinates ' x ' from the GPS/RFID, and computes the distance and direction from ' x ' to the next landmark ' i '. Upon computation of these parameters, the microcontroller sends appropriate signals to the SR motors for navigation.

While in operation, it continuously checks for obstacles using the ultrasonic and infrared sensors mounted on the top of design chassis. The ultrasonic sensor detects obstacles relatively straight ahead whereas the two infrared sensors detect obstacles at a 22.5° angle relative to the front of the robot. To avoid an obstacle, SR uses inputs from all three sensors. Upon identifying any obstacle in its path, it computes a new route to avoid obstacles, and overwrites the route array ' ra '. During travel, the SR provides continuous feedback to the user through the speaker and vibrating motors on the glove. When turning left or right,

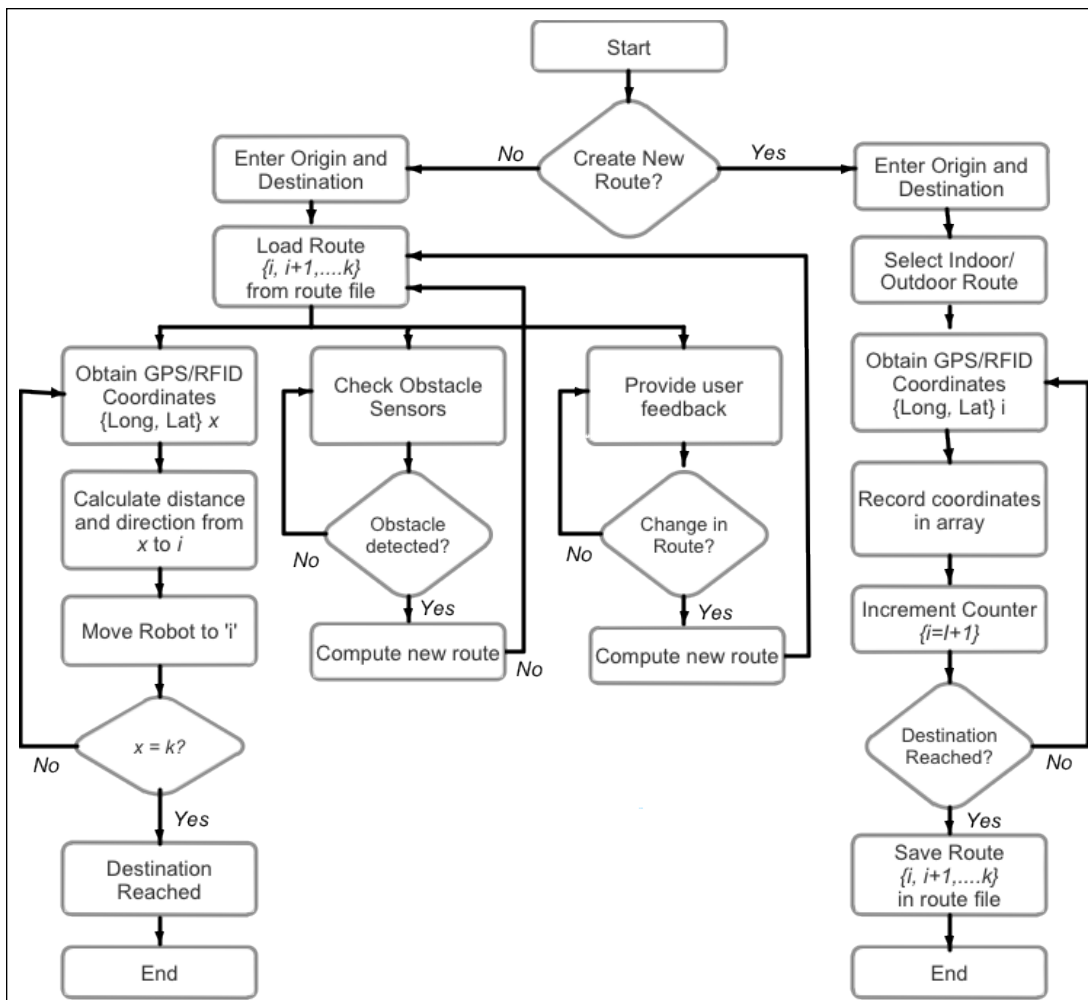

Figure 5: Navigation Algorithm for Smart-Robot

announces the appropriate location information.

If the user intends to create a new route, SR will store the current input as route origin. Later, the direction buttons (left, right, forward, and backwards) on the keypad will be activated. While the user navigates SR to appropriate destination using these buttons, the SR will store the location information (RFID tag UID while indoors, and longitude and latitude coordinates from GSP while outdoors) periodically and store them in a route array " $ra = \{i, i+1, \dots, k\}$ ". Upon reaching the destination, the user presses the "#" button to indicate the destination. Accordingly, the route array 'ra' will be saved into an appropriate route file in the system memory. The route file is then closed and the system returns to the start sequence.

5.2 RFID based Smart-Cane: A Navigational Assistive Device for the Blind

For people with vision disabilities, it has always been difficult to accomplish many day-to-day activities. Identifying different rooms in a building and finding the best route to reach a location is one of the difficult tasks for a person with

motors on the index and ring fingers of the glove vibrate to inform the user of appropriate directional change. Upon reaching each landmark, the speaker

limited or no sight capabilities. Technological advancement such as RFID is the answer for this and many other challenges for people with vision impairments.

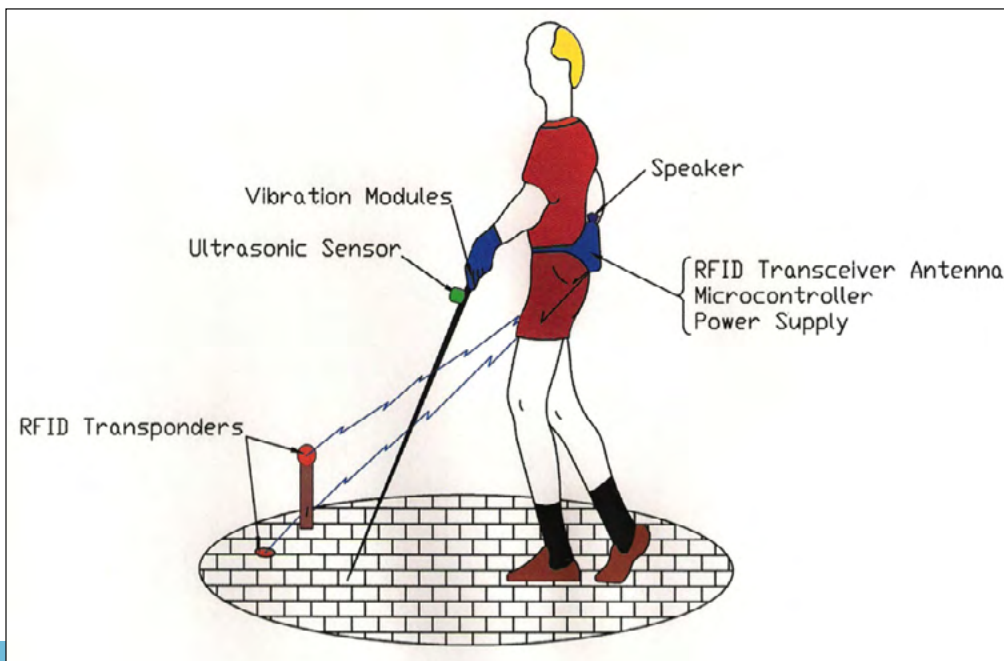

Figure 6: RFID based Smart-Cane

During the fall semester of 2008, four students collaborated to successfully design the RFID based smart-cane shown in Figure 6 (Martin, Dancer, Rock, Zeleny & Yelamarthi, 2009). Utilizing RFID tags for location identification, and ultrasonic sensors for obstacle detection, the smart cane system helps the blind to safely navigate in a predefined environment.

Overall, the concept of utilizing RFID for navigation assistance of the visually impaired is both technically and economically feasible. These *Smart-Robot* and *Smart-Cane* systems help the visually impaired person become less dependent on others to commute, and based on the preliminary user feedback obtained, these devices have been found to provide promising incentive in improving the quality of life. In general, these systems could make the routine tasks of commuting simple and feasible.

6. Conclusion

This paper described a multidisciplinary RFID based assistive device platform to enhance the engineering and technology curriculums. With the majority of the technical concepts already being taught in existing core ET classes, this platform could seamlessly fit into an existing curriculum to educate students in the cutting edge technology. With the majority of the universities housing their Office of Student Disability Services on campus, the proposed model could have a broader impact by providing these disabled students with assistive devices developed by engineering and technology students. This multidisciplinary model could be further enriched based on the strengths at respective institutions. For example, involving students from biomedical engineering programs where available would increase the RFID-AD project scope tremendously.

Upon initial implementation of the projects at the host institution, participating students have reported a very high degree of satisfaction, and published their technical findings at several conferences (Yelamarthi, Haas, Nielsen & Mothersell, 2010; Martin, Dancer, Rock, Zeleny & Yelamarthi, 2009; Haas, Mothersell, Neilsen & Yelamarthi, 2010). In addition, a visually impaired person has tested a prototype, and provided constructive feedback to improve each design. Overall, incorporating RFID-AD projects in ET curriculum has been effective in: a) focusing on undergraduate student academic excellence and preparing them to begin engineering and technology careers as inventors, researchers, and public servants, b) emphasizing both competence and contribution of multidisciplinary designs in the engineering and technology community at large, c) enhancing the students ability to participate in a collaborative and diverse setting, d) designing new instructional resources (labs/design projects) for incorporation into engineering and technology curriculum, and e) engaging students in cutting-edge technologies relevant to real-world applications.

References

- Bureau of Labor Statistics. (2009). CPS disability data: Labor force statistics from the current population survey.
- Bureau of Labor Statistics. (2009). *Occupational outlook handbook, 2008-09 edition*.
- Cardullo, M.W., et al. (1973). Transponder Apparatus and System. *U.S. Patent*, 3,713,148.
- Cavanaugh, T. (2002). The need for assistive technology in educational technology. *Educational Technology Review*, 10(1).]
- Chawla, K., & Robins, G. (2011). An RFID-based object localization framework. *International Journal of Radio Frequency Identification Technology and Applications*, 3(1), 2-30.
- Dutson, A.J., Todd, R.H., Magleby, S.P., & Sorenson, C.D. (1997). A review of literature on teaching engineering design through project-oriented capstone courses. *Journal of Engineering Education*, 86(1), 17-28.
- Field, M., & Jette, A.M. (2007). *The future of disability in America*. The National Academy of Press.
- Friedman, T.L. (2005). *The world is flat: A brief history of the twenty-first century*. New York: Farrar, Straus, and Giroux.
- Haddara, M., & Skanes, H. (2007). A reflection on cooperative education: From experience to experiential learning. *Asia-Pacific Journal of Cooperative Education*, 8(1), 67-76.
- Hefzy, M.S., Pourazady, M., & Afjeh, A.A. (2008). Engineering senior design projects to aid individuals with disabilities. *Proceedings of ASEE Annual Conference and Exposition*, June 22-25, Pittsburgh, PA.
- National Academy of Engineering. (2004). *The engineer of 2020: Visions of engineering in the new century*.
- National Science Board. (2012). *Science and engineering indicators digest 2012*. Arlington, VA: National Science Foundation, NSB 12-02.
- Nikitin, P.V., & Rao, K.V.S. (2006). Theory and measurement of backscattering from RFID tags. *IEEE Antennas and Propagation Magazine*, 48(6), 212-218.
- Schaefer, D., Panchal, J.H., Choi, S-K., & Mistree, F. (2008). Strategic design of engineering education for the flat world. *International Journal of Engineering Education*, 24(2), 247-282.
- Scherer, M.J., & Glueckauf, R.L. (2005). Assessing the benefits of assistive technologies for activities and participation. *Rehabilitation Psychology*, 50(2), 132-141.
- Skates, G.W. (2003). Multidisciplinary project working in engineering education. *European Journal of Engineering Education*, 28(2), 187-201.
- Terpenny, J. (2006). Introduction to assistive technology and universal design. *Assistive Technology Design Project*, Virginia Polytechnic Institute and State University.
- U.S. Census Bureau. (2008). *Americans with disabilities: 2005*.
- Yelamarthi, K. Haas, D. Nielsen, D., & Mothersell, S. (2010). RFID and GPS navigation system for the visually impaired. *IEEE International Midwest Symposium on Circuits and Systems*, August, 1149-1152.

Kumar Yelamarthi received his Ph.D. degree from Wright State University, Dayton, OH in 2008, in electrical engineering. He is currently an Assistant Professor of Electrical Engineering at Central Michigan University, Mt Pleasant, MI. His research interest is in the area of timing optimization, computer-aided design, semiconductor process variations, multi-disciplinary VLSI design, and engineering education. He has served as



a technical reviewer for several IEEE/ASME/ASEE international conferences and journals, and has written over 50 publications in both technical and educational fields. He is a member of Tau Beta Pi engineering honor society, and Omicron Delta Kappa national leadership honor society.

Copyright of Journal of STEM Education: Innovations & Research is the property of Institute for SMET Education & Research and its content may not be copied or emailed to multiple sites or posted to a listserv without the copyright holder's express written permission. However, users may print, download, or email articles for individual use.